

F (1 : 2)

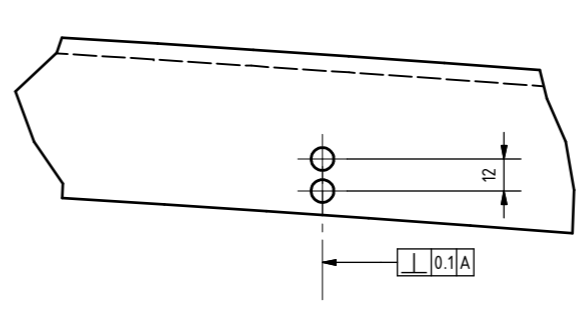

E (1 : 2)

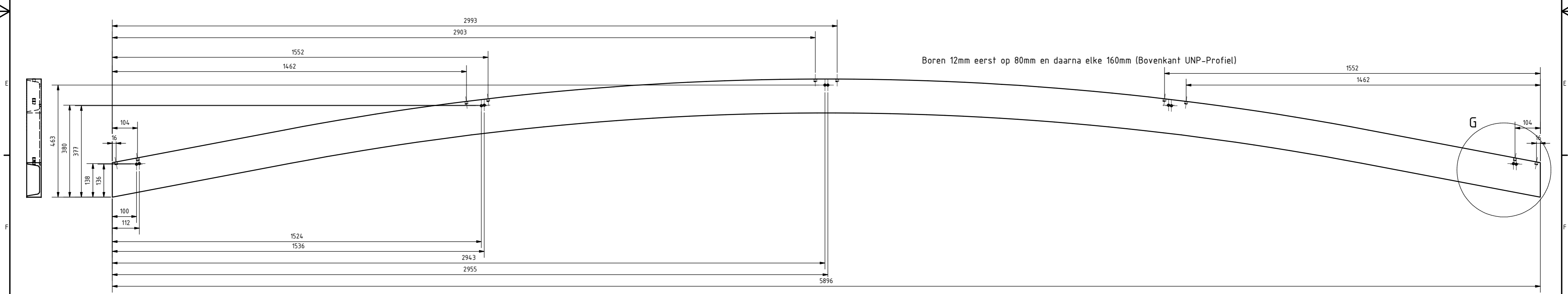
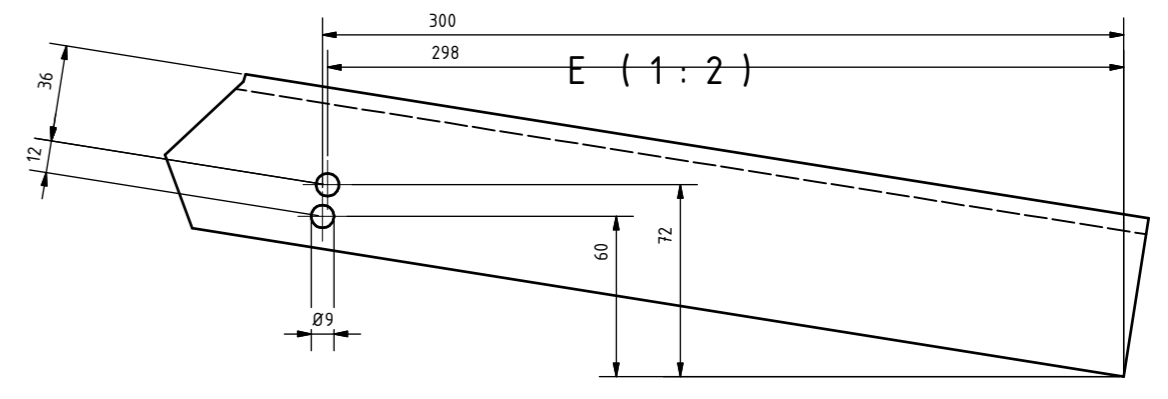

G (1 : 2)

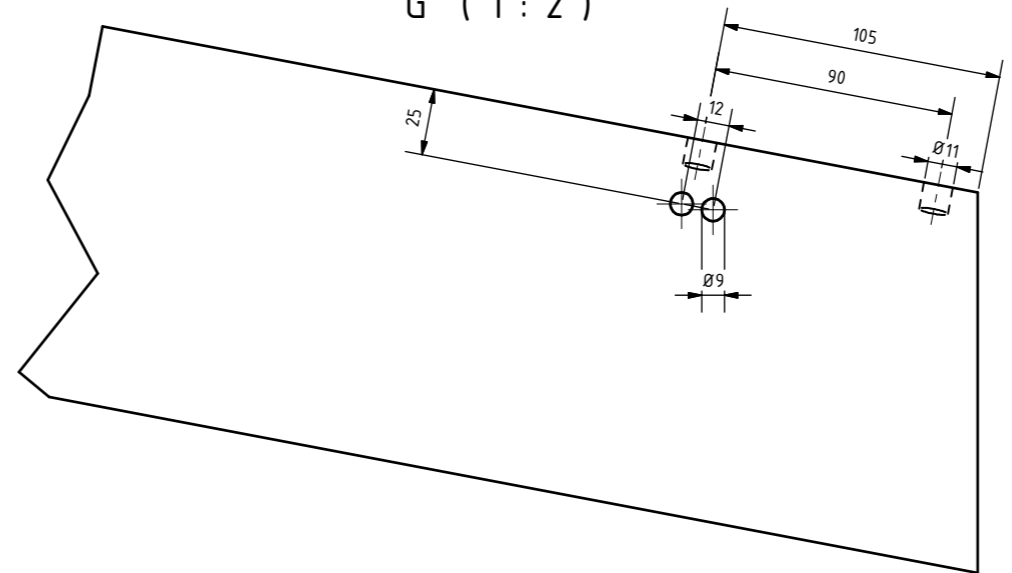

1	2	UNP PROFIEL 140	FE 235	L=6000	BUIGEN r 12 000
2	2	HOEKLIJN	FE 235	L60*60*6 L6000	BUIGEN r 14, 200
STUK	AAN	BENAMING	MATERIAAL EN/OF	NORMAANDUIDING OF AFMET	OPMERKINGEN
		RUIWHEID VOLGENS NEN 3634	ISO-PASSINGEN NEN-ISO 286-1 EN-2		
		AMERIKAANSE PROJECTIE	SCHAAL 1:8	GETEKEND S VAN HAL & T V/D BERG	VORM- EN PLAATSTOLERANTIES VOLGENS NEN-ISO 1101
			MAATEENHEID MM	KLAS VTMD24	
			DATUM 19-6-2007	GEZIEN	
		ROC A12	Benaming	HOEK EN UNP PROFIEL	Tekening Nr. 1 Formaat A1